

FILTER SYSTEM MAINTENANCE



Normal maintenance suggested for all Solimar Filters is a three part process that includes:

BACKFLUSHING	Every load / unload cycle	Reverse the flow of blower air from clean side to filtered side to "flush" loose filtered particles from the filter element and improve performance.
INSPECTION	Every 2 months	Remove filter retainer plate. Randomly remove and visual inspection filter elements for damage.
CLEANING	Every 6 months	Backflush filter elements with an air nozzle. Wash with warm water (max 80°C/ 175°F) and mild household detergent. Upon reassembly run blower air through filter to dry the elements.

For inspection, cleaning and ease of handling, the filter assembly can be removed by removing the (12) $\frac{3}{8}$ " locknuts on the outside radius and then using the lift handle in the center of the filter to remove.

The retaining plate is removed by the inner radius of locknuts.

Note: Install rubber grommets with each element and be ensure it is seated in the plate prior to reassembly.

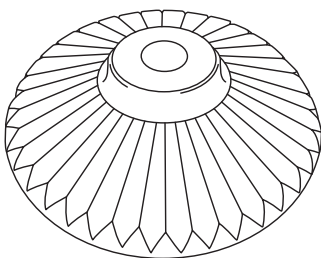
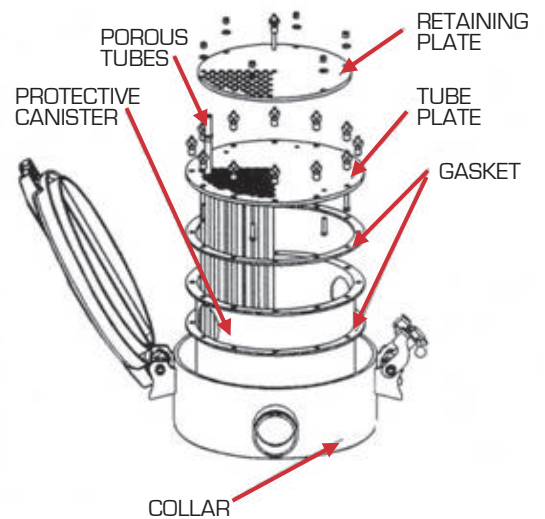

**INSIST ON GENUINE
SOLIMAR DISKS WITH
THE TRADEMARKED
RADIAL RIDGE DESIGN**