

# DISK FLUIDIZER INSTALLATION INSTRUCTIONS

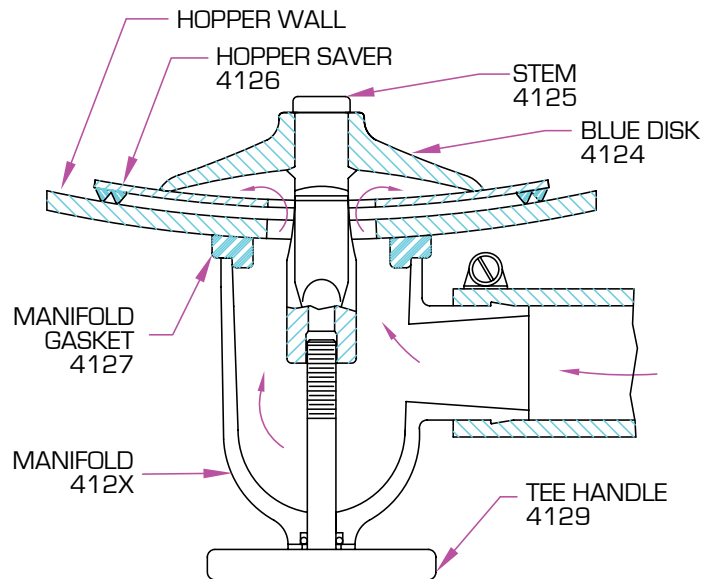

## New Trailers

1. Inside: Insert the stem (4125) into the Hopper Saver (4126) through the hole in center with the rubber coated side facing the inside hopper wall. Orient the "I" up. Put the assembly in place.
2. Outside: Insert the Tee handle assembly (4129) into Manifold (412X). Put Manifold Gasket (4127) in open end of Manifold, flat side out, locating ring inside Manifold. Place Manifold over protruding Fluidizer Stem and engage Tee Handle in stem threads. Turn the Tee Handle until Manifold Gasket makes full contact with hopper. Give Tee Handle three additional twists (1 ½ full 360° turns). DO NOT OVERTIGHTEN. If the assembly has a standard bolt, tighten to 25 in/lbs.

## Retro Fitting

1. Check if any product remains in hoppers. If so, open product valves so product can be pushed down into the line.
2. Remove only one Manifold at a time.
3. When going inside tank, bring all new Fluidizers, Hopper Savers, a putty knife, a wire brush, a rag and a ¾" open end wrench.
4. Remove existing aeration devices including any gaskets from inside tank.
5. To assure best seal against the hopper, clean hopper surface thoroughly. Remove any loose and caked material by scraping, wire brushing and wiping. Avoid any chipping action since it dents hopper surface and impedes gravity flow.
6. Repeat steps (1) and (2) for new trailers. If Fluidizer wants to turn inside hopper, hold top of stem with ¾" wrench.

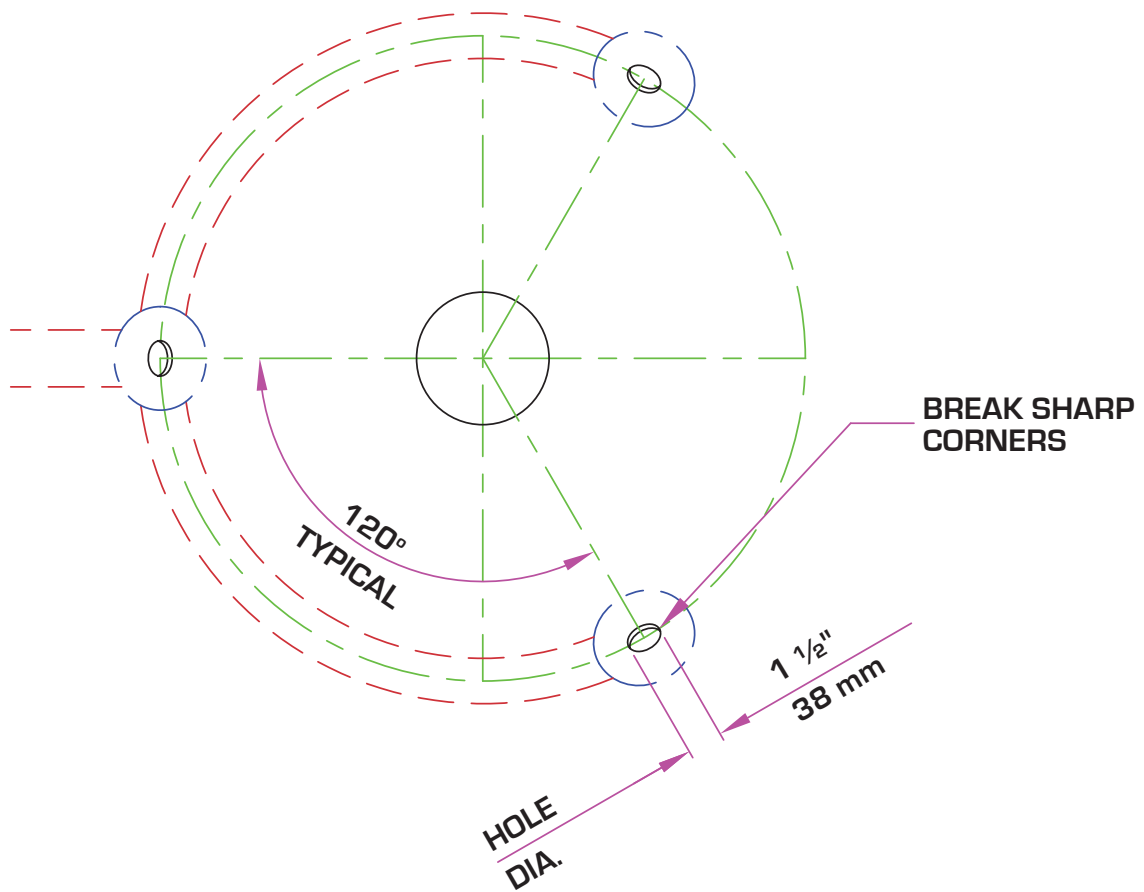

**SOLIMAR STANDARD AERATION SYSTEM  
FOR MULTI HOPPER TRAILERS**

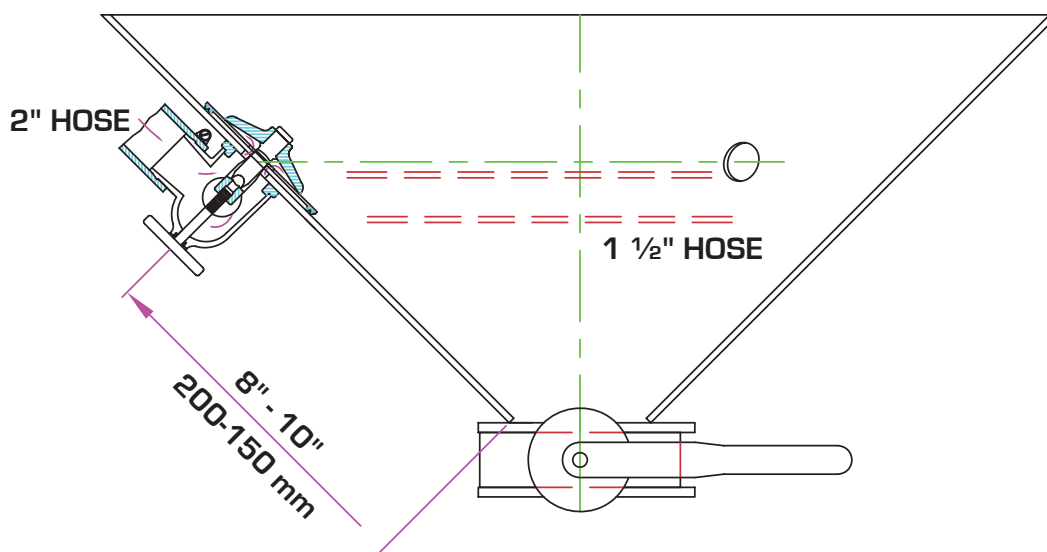

# 索利玛尔拖车流化器 定期维护日程



索利玛尔流化器系统只需要很少的维护。然而，应当进行定期目视检查以查验磨损情况。

## 每六个月检查 拖车的内部

1. 检查流化器盘的磨损情况。流化盘应当在索利玛尔料斗保护器或拖车料斗壁（如果未使用料斗保护器）上压紧和密封。检查流化盘是否磨损不均匀。如果外缘一侧不再圆整，则此迹象表明气流不均，应该更换流化盘。
2. 检查确认产品无堆积，盘下无硬结产品。这些产品可以通过拆卸盘与导杆组件来清理。
3. 查看索利玛尔料斗保护器的磨损情况。料斗保护器应当紧贴在拖车料斗壁上。如果料斗保护器显示异常磨损，或者如果橡胶材料从不锈钢防磨板内暴露出来，则应当更换料斗保护器。如果拖车中没有使用索利玛尔料斗保护器，则检查拖车料斗壁的磨损情况。注意：索利玛尔强烈推荐在拖车运输磨蚀性产品，比如水泥和砂子时使用料斗保护器。

## 每年检查 拖车的外侧

1. 检查确认歧管垫圈没有被紧固过度的T形把手或螺栓组件损坏。如果垫圈出现损坏，则应当更换。

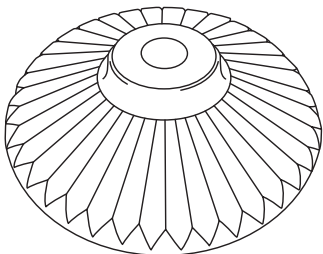

请认准索利玛尔带有放射  
状突脊商标设计的原厂盘  
件